

# FHD0 - FLOOR GRILLES

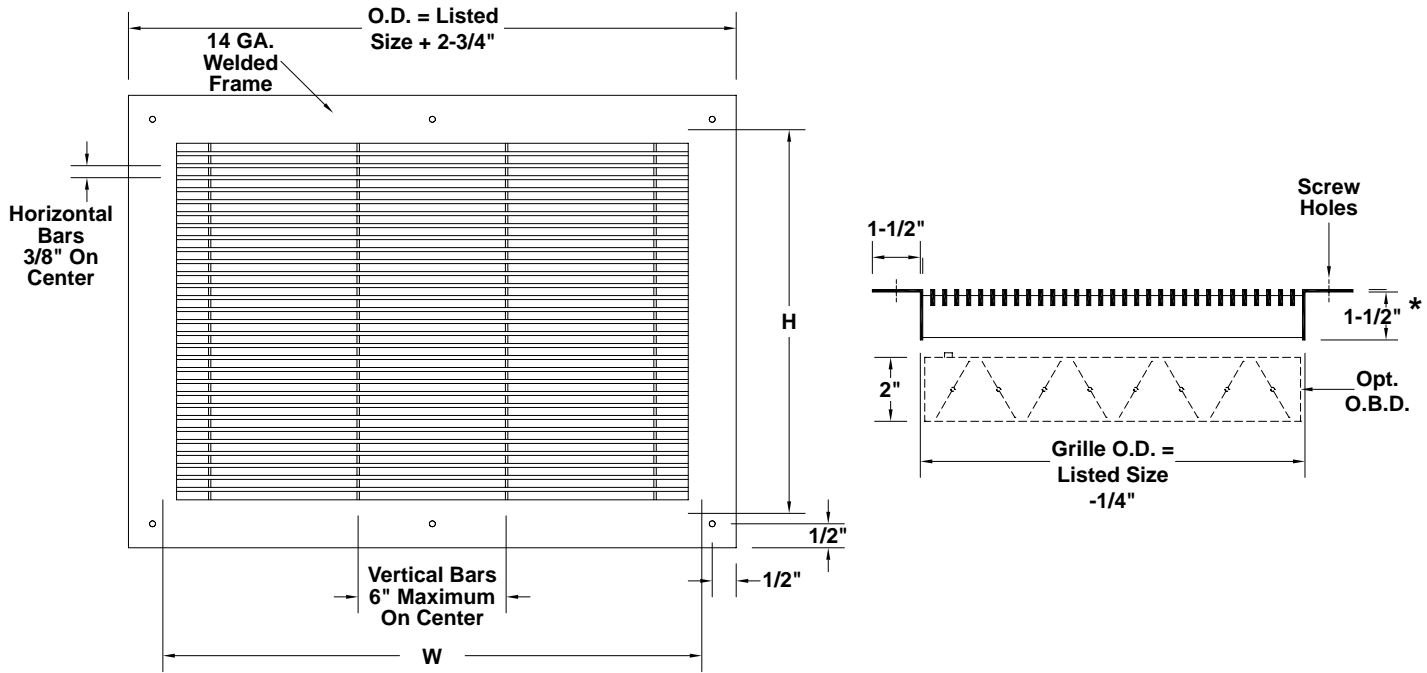

**STANDARD FEATURES:**

- 0° blade deflection is standard, specify Model FHD0.
- All welded, heavy steel construction. 14 ga. steel sleeve and face plate. Other gauges available.
- 1/8" x 1/2" horizontal blades, 3/8" centers supported by 14 gauge vertical bars on 6" centers. Other blade / support bar spacing available.
- Countersunk screw holes, maximum 10" centers and flat head screws are standard for surface mounting.

**STANDARD FINISH:**

- Steel - white 2-component polyurethane finish.
- Aluminum - mill finish or white
- Stainless steel - 304 or 316 satin finish

\* 4" sleeve length with optional O.B.D.  
 \* 1-1/2" minimum sleeve length; grilles over 14" high may have extended sleeve as required.

**OPTIONS:**

- Aluminum construction (.125")
- Stainless steel construction (12 ga.)
- Extended sleeve
- Opposed blade damper
- No screw holes
- Concealed mounting, Option G
- Two-part polyurethane white finish (stainless steel)
- Other paint finishes
- Mill finish (industrial grade) blades (stainless steel only)
- Clear or bronze anodized (aluminum only)
- Security screws

**Mounting Option G**  
Fastening Lugs

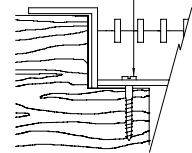

Qty.	Listed Size		Material	Finish	Damper	Screw Holes	Debris Screen	Other Options	Tag
	W	H							

To maintain KEES' policy of continuous product development, we reserve the right to change prices, specifications, ratings and dimensions without notice or obligation.

<b>Project</b>				<b>Location</b>						
<b>Engineer</b>				<b>Dwg. No.</b>	<b>SD-FHD</b>					
<b>Architect</b>				<b>Date</b>	<b>09/14</b>					
<b>Contractor</b>										



**KEES INCORPORATED**  
 400 S. Industrial Dr.  
 Elkhart Lake, WI 53020  
 Phone: (920) 876-3391  
 Fax: (920) 876-3065  
 Website: www.kees.com