

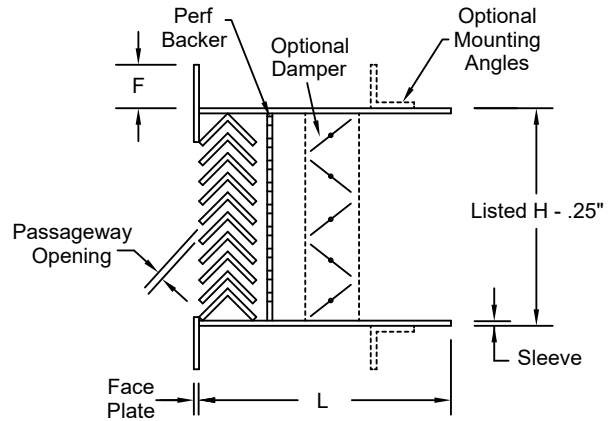

MAXIMUM SECURITY RISK RESISTANT "V" PASSAGEWAY GRILLE WITH PERFORATED BACKER

Model SEG-13P

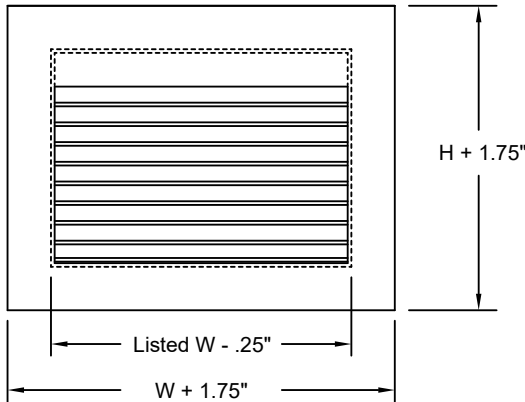

QTY	LISTED SIZE		SLEEVE O.D.		SLEEVE LENGTH L	ACCESSORIES	MOUNTING OPTION	TAG
	W	H	W	H				

STANDARD CONSTRUCTION

- 12-gauge steel
- "V" louvers with 3/16" openings
- Perforated backer with 1/8" dia. holes on 3/16" centers
- 1" flange stitch welded
- Sleeve continuously welded
- White two-part polyurethane finish

OPTIONS

FACE MATERIAL

- 12-gauge steel (Std.)
- 14-gauge steel
- 3/16" steel
- Other _____

LOUVER MATERIAL

- 12-gauge steel (Std.)
- Other _____

PASSAGEWAY OPENINGS

- 3/16" (Std.)
- 1/8"
- 3/8"
- Other _____

FLANGE "F"

- 1" (Std.)
- Other _____

SLEEVE MATERIAL

- 12-gauge steel (Std.)
- 14-gauge steel
- 3/16" steel
- Other _____

FINISH

- White (Std.)
- Other _____

OTHER MATERIAL

- Aluminum (SEG-13P)
- 304 SS (SEG-13PSS)

ACCESSORIES

- 16R. Rear operated opposed blade damper tack welded into sleeve. Dampers are adjustable using flat bladed screwdriver.
- 19. 1/2" dia. A-36 mild steel security bars 6" o.c. both ways, welded to sleeve and at intersections.
- Other _____

MOUNTING

- 11A. Two loose pieces of 1" x 1" x 3/16" mill finish steel angle loose for field welding to sleeve. Length equal to longest side of grille. Other angle size _____
- 11B. Rear angle frame of 1" x 1" x 3/16" mill finish steel completely assembled for field welding to sleeve. Other angle size _____
- 12A. Rear angle frame for bolting to sleeve. 1" x 1" x 3/16" steel with bolt holes 8" o.c. for 1/4" dia. bolts. No holes in sleeve. No bolts, nuts or washers. Other angle size _____
- 12B. Same as 12A with the addition of bolt holes in sleeve. (Advise wall or ceiling thickness) Other angle size _____
- 23. Masonry anchors: 1/2" x 3" anchors 16" o.c., one per side minimum, welded to sleeve exterior. Other sizes or spacing _____
- 24. Countersunk screw holes in face 10" o.c. with #10-24 x 2" long Torx security machine screws for 1-1/2" maximum ceiling thickness. 1" x 1" x 1/8" steel angle frame with matching holes and foldover nuts. Requires 1-1/2" flange.
- 25. Countersunk screw holes in face 10" o.c. with #10 x 1-1/2" long Torx security sheet metal screws. Other screw length _____

To maintain KEES' policy of continuous product improvement, we reserve the right to change prices, specifications, ratings or dimensions without notice or obligation.

Project/Location		KEES INCORPORATED 400 South Industrial Drive Elkhart Lake, WI 53020 Ph: 920.876.3391 www.kees.com
Engineer/Architect		
Contractor		
Representative		Date