

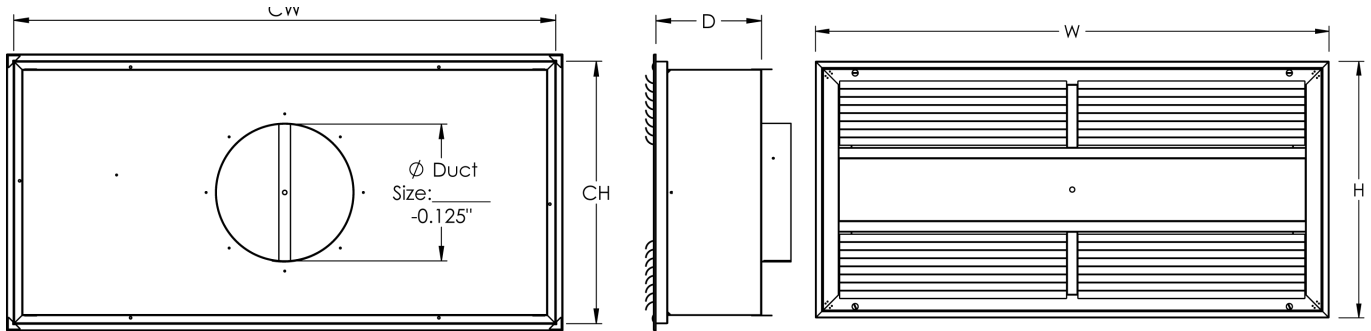

HEMISPHERICAL DIFFUSER

Model HSD



AVAILABLE FEATURES

STANDARD CONSTRUCTION

- 304 Stainless Steel
- 51% Perf Face
- Seam Welded Plenum Corners
- Lay-In / Surface Mounting
- Walkable Plenum up to 250lbs
- Hanger Tabs for Unit Support Above Ceiling

FEATURE OPTIONS

- Louvered Center Section – 0° Deflection
- Foil Backed Insulation
 - 1.5" (R=4.2)
 - 2.25" (R=6.0)
- HEPA-Lert Filter Monitor
 - Battery
 - 24V Supply (By Others)
- Test Ports
 - 1 Port
 - 2 Ports
- PAO Challenge System (Requires 2 Test Ports)
- Seam Welded Inlet Collar
- Hard Ceiling Clamping System

- Hanger Brackets (for use with 3/8" threaded rod by others)
- Custom Unit Depth: _____

FINISH OPTIONS

- Polished
- White Antimicrobial Powder Coat
- Other: _____

MATERIAL OPTIONS

- 304 Stainless Steel (Std.)
- 316 Stainless Steel

INLET OPTIONS

- Inlet Location
 - Top Inlet
 - Side Inlet
 - End Inlet
- Inlet Shape/Size
 - Round – Size: _____
 - Oval – Size: _____
 - Rectangle – Size: _____
 - Flanged



HEMISPHERICAL DIFFUSER

Model HSD

FILTER OPTIONS

- H14 HEPA Filter – 99.995% on 0.3 μ m
- ULPA Filter – 99.9995% on 0.12 μ m

DAMPER OPTIONS

- Remote Damper (*Not Available w/Disc Damper*)

DAMPER OPTIONS

- SSRD – Butterfly Damper
- SSBD – Bowtie Damper
- SSDD – Disc Damper
 - Solid Disc
 - Solid Disc w/Perf Ring
 - Perf Disc

NOMINAL UNIT SIZE	OVERALL WIDTH (W)	OVERALL HEIGHT (H)	DEPTH (D)	CUTOUT WIDTH (CW)	CUTOUT HEIGHT (CH)	FILTER	FILTER DEPTH (D)	ACTIVE FILTER FACE AREA (SQ.FT.)
24 X 24	23.75	23.75	6.00	23.00	23.00	RSR	9.00	2.00
36 X 24	35.75	23.75	6.00	35.00	23.00		9.00	3.42
48 X 24	47.75	23.75	6.00	47.00	23.00		9.00	4.84

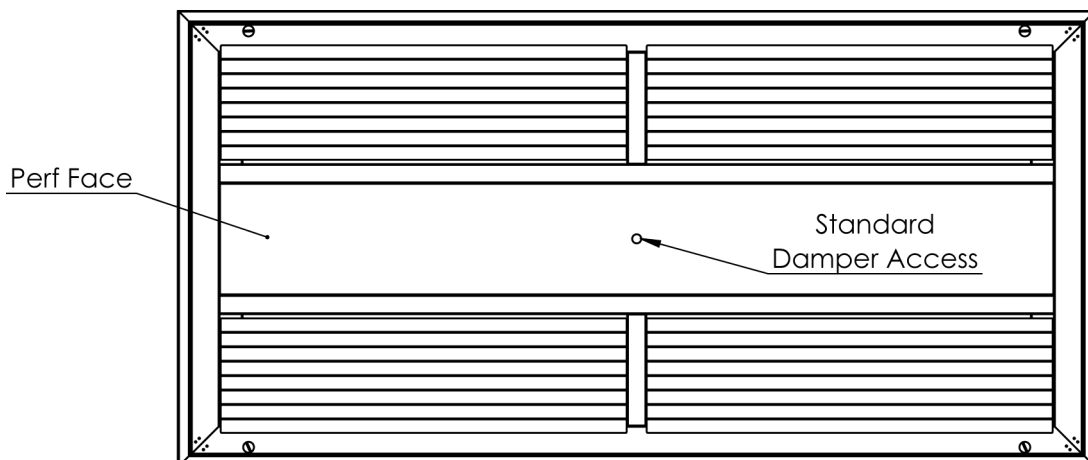



HEMISPHERICAL DIFFUSER

Model HSD

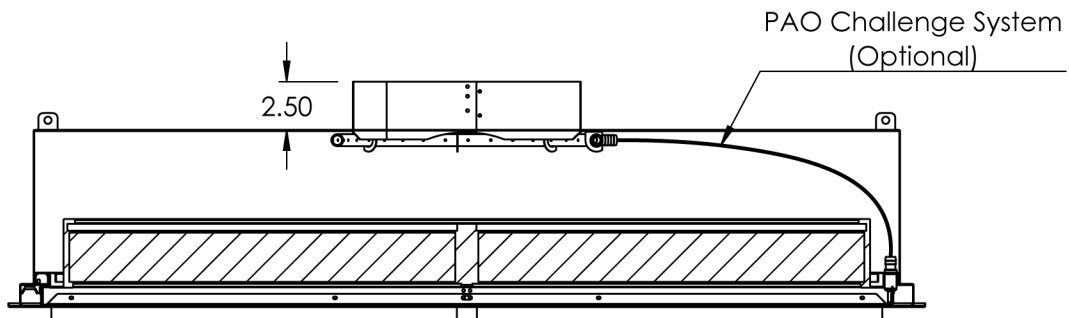
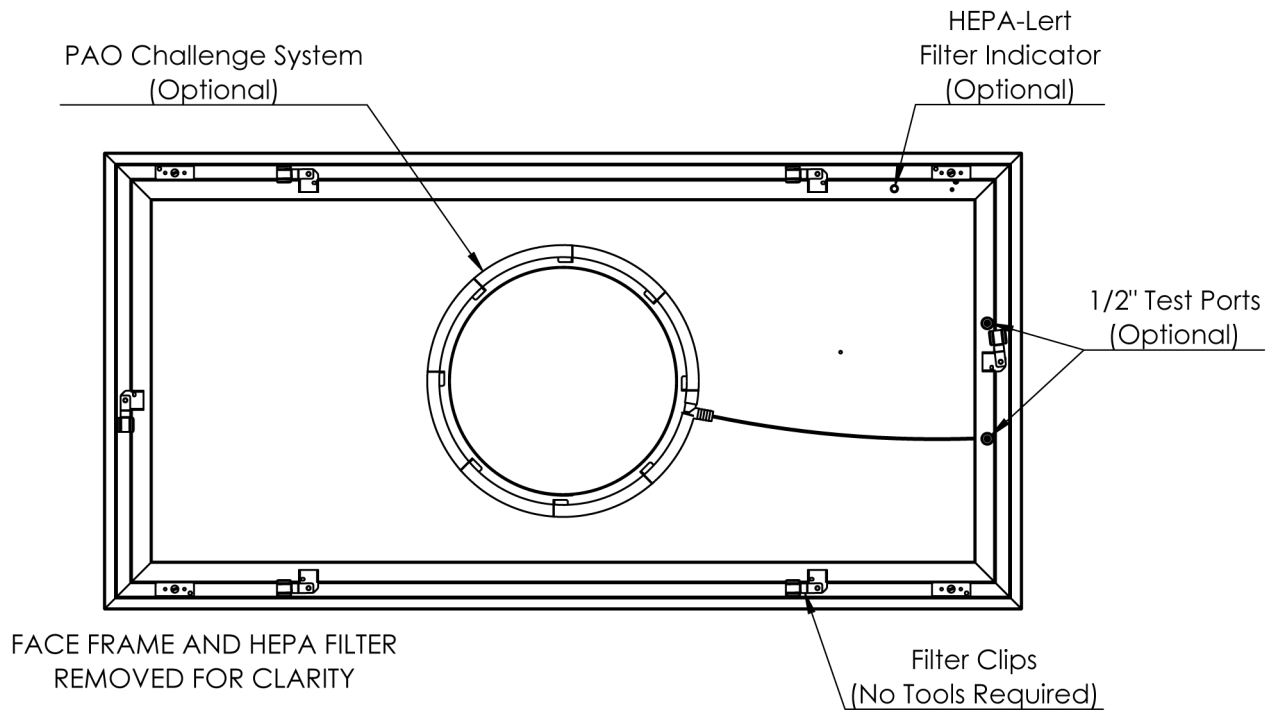



HEMISPHERICAL DIFFUSER

Model HSD

