



RADIAL DIFFUSER

Model RD

AVAILABLE FEATURES

STANDARD CONSTRUCTION

- 304 Stainless Steel
- Seam Welded Plenum Corners
- Lay-In / Surface Mounting
- Walkable Plenum up to 250lbs
- Hanger Tabs for Unit Support Above Ceiling

AIRFLOW PATTERNS

- 1-Way
- 2-Way

FACE OPTIONS

- Flat Face 51% Perf
- Hinged Face 13% Perf

FEATURE OPTIONS

- Foil Backed Insulation
 - 1.5" (R=4.2)
 - 2.25" (R=6.0)
- Change Filter Monitor
 - Battery
 - 24V Supply (By Others)
- Test Ports
 - 1 Port
 - 2 Ports
- PAO Test System (*Requires 2 Test Ports*)
- Seam Welded Inlet Collar
- Hard Ceiling Clamping System
- Drop Face
- Hanger Brackets (*for use with 3/8" threaded rod by others*)
- Custom Unit Depth: _____

INLET OPTIONS

- Inlet Location
 - Top Inlet
 - Side Inlet
 - End Inlet
- Inlet Shape/Size
 - Round – Size: _____
 - Oval – Size: _____
 - Rectangle – Size: _____
 - Flanged

MATERIAL OPTIONS

- 304 Stainless Steel (Std.)
- 316 Stainless Steel

FINISH OPTIONS

- Satin
- White Antimicrobial Powder Coat
- Other: _____

FILTER OPTIONS

- H14 HEPA Filter - 99.995% on 0.3 μ m
- ULPA Filter - 99.9995% on 0.12 μ m
- No Filter

DAMPER OPTIONS

- Butterfly Damper
- Bowtie Damper
- Remote Damper



RADIAL DIFFUSER

Model RD

RADIAL DIFFUSER FLAT FACE

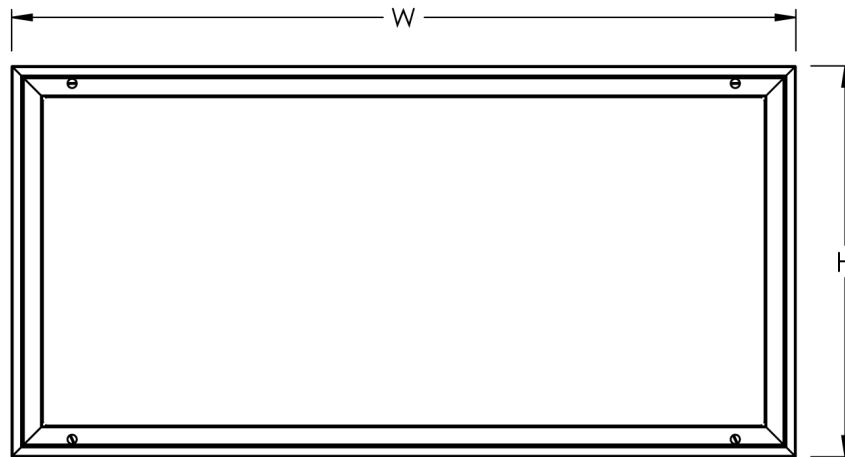
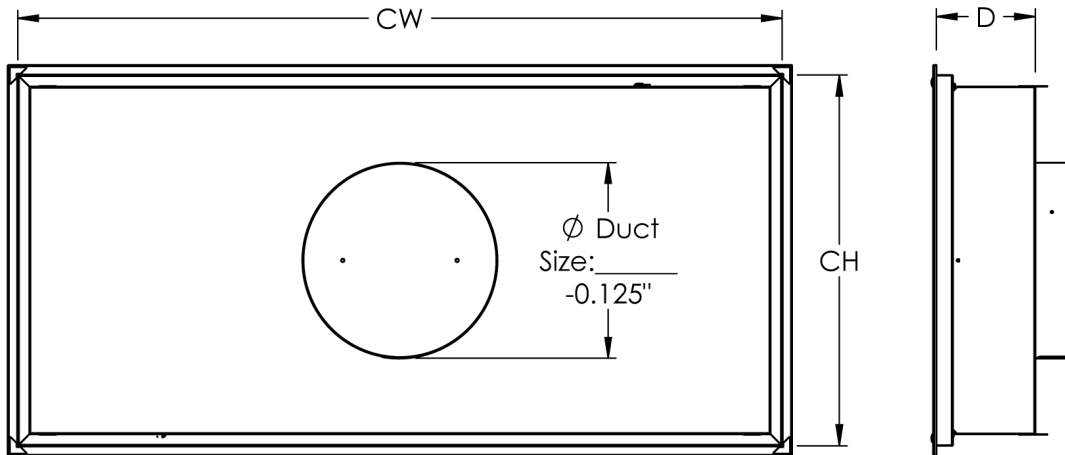

NOMINAL UNIT SIZE	OVERALL WIDTH (W)	OVERALL HEIGHT (H)	DEPTH (D)	CUTOUT WIDTH (CW)	CUTOUT HEIGHT (CH)	WITH FILTER		
						FILTER	DEPTH (D)	ACTIVE FILTER FACE AREA (SQ.FT.)
24 X 24	23.75	23.75	6.00	23.00	23.00	From Room	9.00	2.00
36 X 24	35.75	23.75	6.00	35.00	23.00		9.00	3.42
48 X 24	47.75	23.75	6.00	47.00	23.00		9.00	4.84



RADIAL DIFFUSER

Model RD

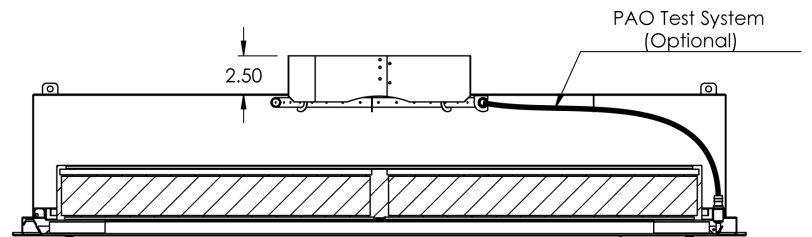
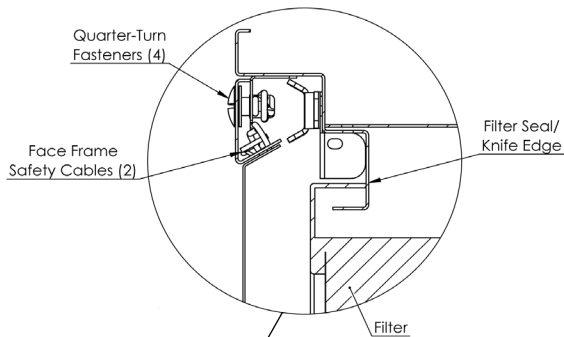
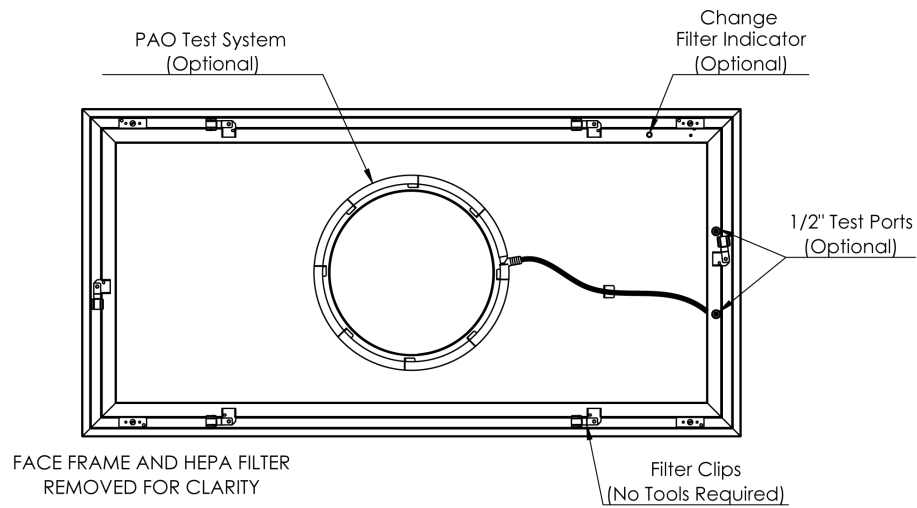

SECTION A-A

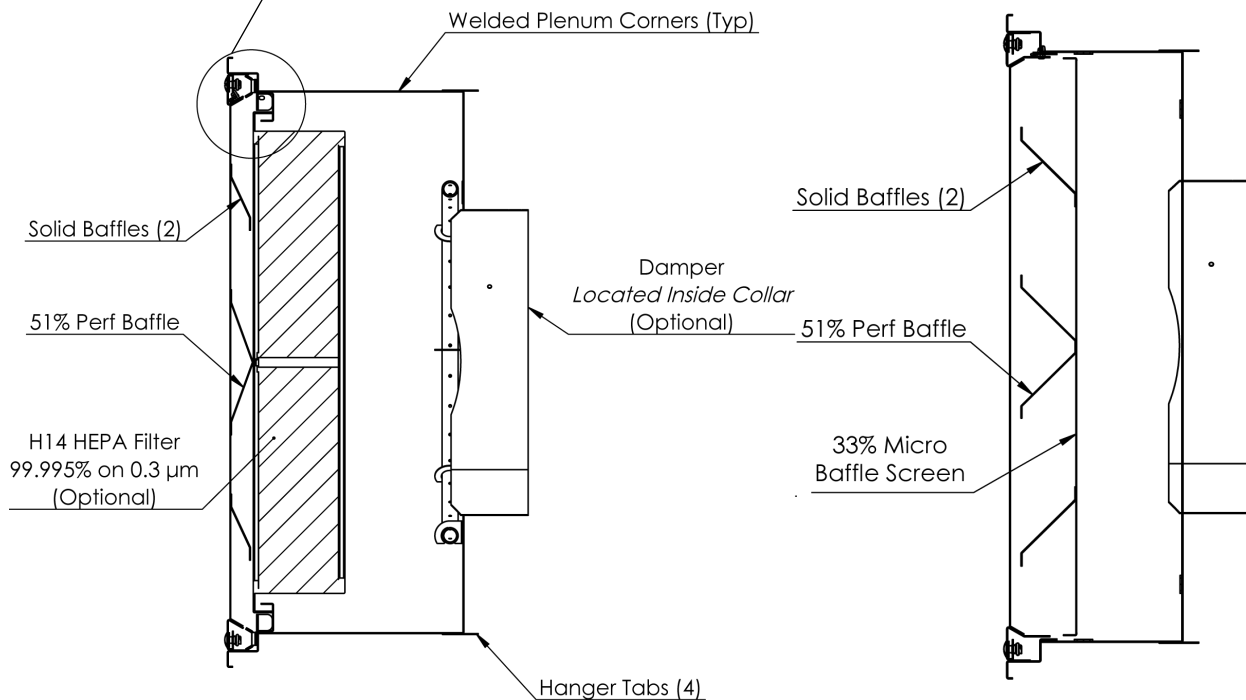

1-WAY AIRFLOW
(SHOWN WITH FILTER)

2-WAY AIRFLOW



RADIAL DIFFUSER

Model RD

RADIAL DIFFUSER ROUNDED FACE

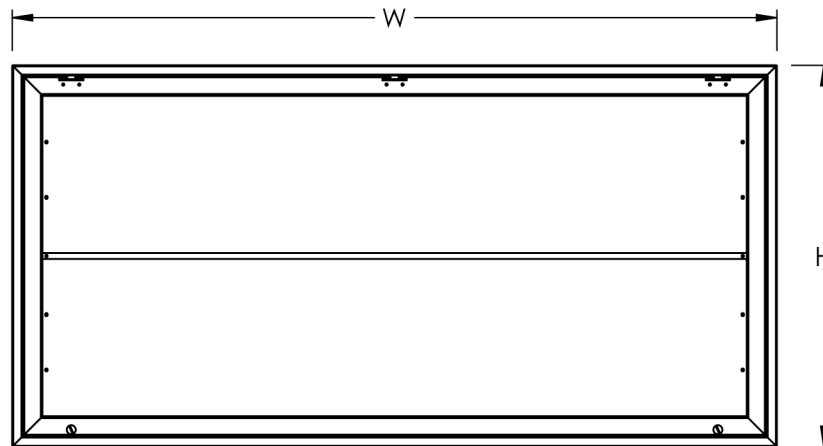
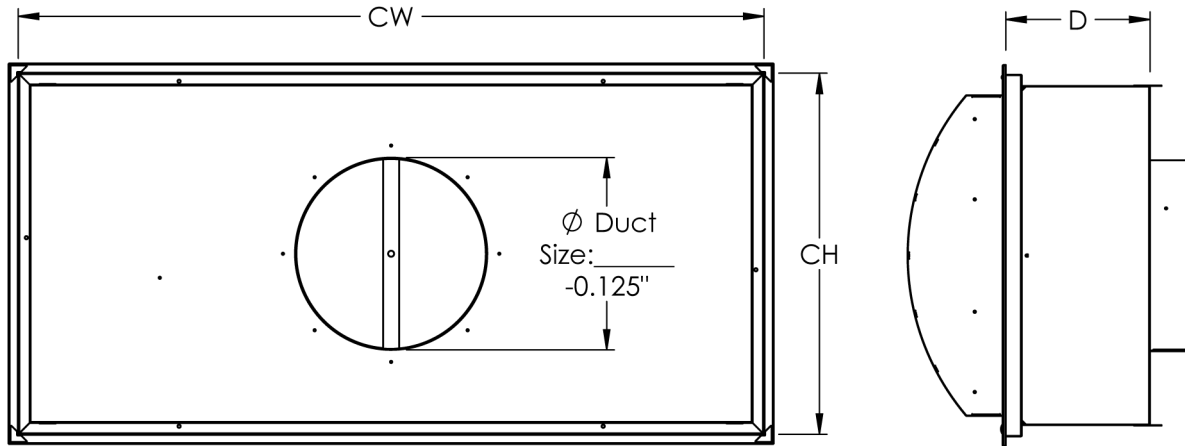

NOMINAL UNIT SIZE	OVERALL WIDTH (W)	OVERALL HEIGHT (H)	DEPTH (D)	CUTOUT WIDTH (CW)	CUTOUT HEIGHT (CH)	WITH FILTER		
						FILTER	DEPTH (D)	ACTIVE FILTER FACE AREA (SQ.FT.)
24 x 24	23.75	23.75	6.00	23.00	23.00	From Room	9.00	2.00
36 x 24	35.75	23.75	6.00	35.00	23.00		9.00	3.42
48 x 24	47.75	23.75	6.00	47.00	23.00		9.00	4.84



RADIAL DIFFUSER

Model RD

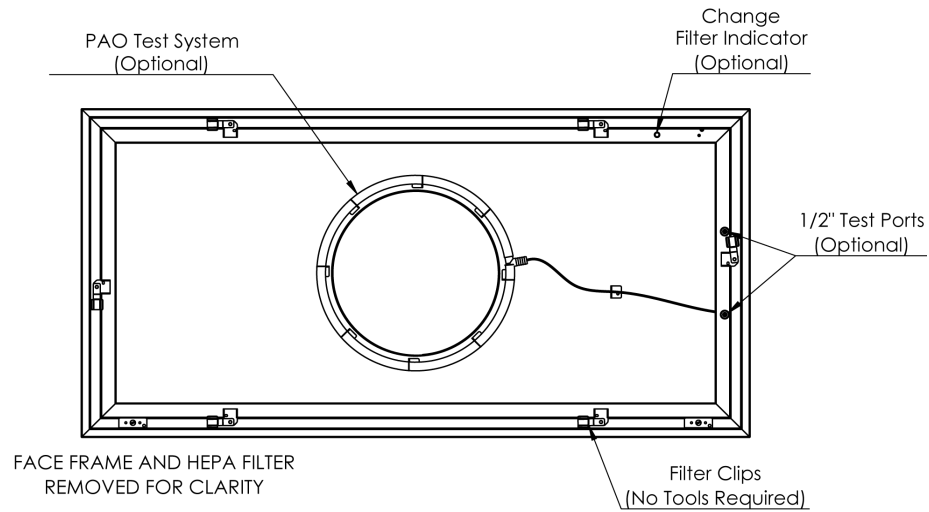

1-WAY AIRFLOW

(SHOWN WITH FILTER)

2-WAY AIRFLOW

